

CONDITION ASSESSMENT AND RECOMMENDATIONS

Butler-Perozzi Fountain Lithia Park

*Architecture
Planning
Conservation*

Ashland Parks Foundation / July 26, 2022, Rev. 01 October 05 2022



Architectural
Resources Group

CLIENT:

Ashland Parks Foundation
PO Box 247
Ashland, OR 97520

Mike Gardiner
President

Donna Rhee
Vice President

Michael Murray
Treasurer

Jeff Mangin
Secretary

Mark Knox
At Large Member

Jim Lewis
APRC Commissioner Appointee

ARCHITECT:

Architectural Resources Group, Inc.
720 SW Washington Street
Suite 605
Portland, OR 97205

Maya Foty, AIA
Principal-in-charge

Jennifer Pont, AIC Professional Associate, APT
Associate, Conservator

FOUNTAIN CONSULTANT:

Lance Dohman
Aquatic Environments

COST ESTIMATE:

Jennifer Correia
*Architectural Resources Group-Conservation Services,
Inc.*



Table of Contents

1. Introduction	1
1.1 Executive Summary	
1.2 Description and Brief History	
2. Methodology.....	5
2.1 On-Site Assessment	
2.2 Cost Estimate	
2.3 Guidelines	
3. Existing Conditions.....	7
3.1 Summary of Conditions	
3.2 Fountain	
3.3 Terrace	
3.4 Main Staircase	
4. Recommendations	19
4.1 Fountain	
4.2 Terrace	
4.3 Main Staircase	
4.4 Discussion: Rehabilitation vs. Replacement	
Appendices.....	24
A. Existing Conditions Survey	
B. Roman Fountains Custom Vault Cut Sheet	
C. Cost Estimate by ARG/CS	

This page intentionally left blank.

Section One

Introduction

Architectural Resources Group, Inc. (ARG) was retained by the Ashland Parks and Recreation Commission to assess the Butler-Perozzi Fountain, located in Lithia Park, in Ashland, Oregon and provide recommendations for its repair and restoration.

The fountain sits at the top of a concrete terrace at the west side of the park. The goal of this assessment was to document the current condition of the fountain and the terrace where it sits and provide repair and upgrade recommendations to return the fountain and terrace to its former glory as a beloved piece of the landscape at Lithia Park.

EXECUTIVE SUMMARY

Overall the fountain and terrace are in fair condition, with certain elements in fair to poor condition. The fountain was running at the time of the assessment, demonstrating that the recirculating pump system performs its basic function while emphasizing significant issues including uneven flow through the various water elements, including splashing and a tipping condition in the uppermost bowl.

Most of the marble fountain is in fair condition, with previous repairs ranging from intact stone dutchman to missing stone dutchman and failed epoxy repairs. There are significant open and

failed joints, especially near the water line at the lower pedestal and lower bowl that feeds into the fountain pool.

The concrete of the terrace and stairs is in fair condition, with certain elements in poor condition. The most common condition is cracking and spalling due to failed previous repairs and corroding ferrous reinforcement. These conditions are present at most of the light posts, and short columns.

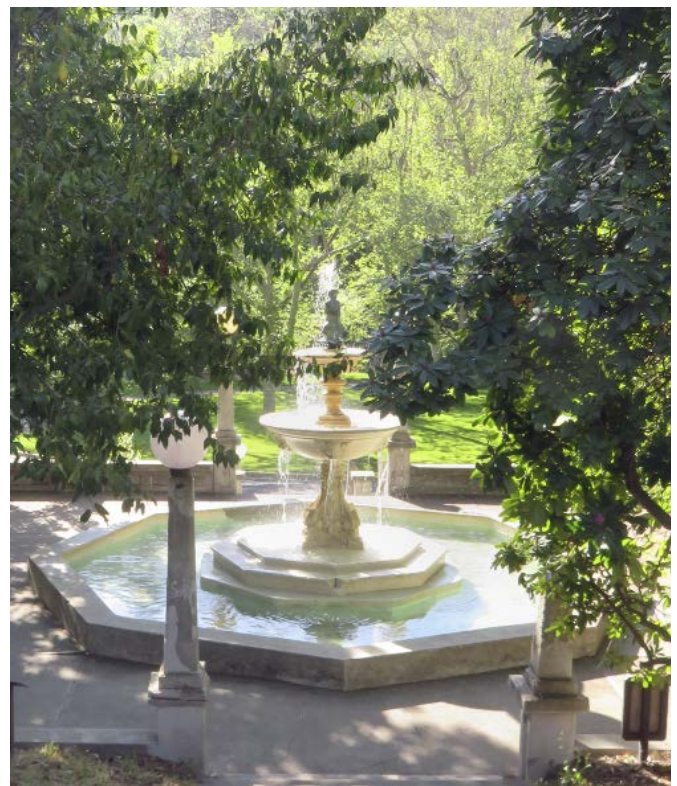

Fountain viewed from steps to Granite Street.

Introduction

DESCRIPTION AND BRIEF HISTORY

The Butler-Perozzi fountain is composed of three-tiered marble bowls and pedestals, and is capped with a small bronze statue of a boy and duck which spits water into the uppermost bowl that then cascades into the middle bowl where water flows over a weir edge. Water then flows through lionhead scuppers on the underside. The pedestal of the lower bowl has additional water elements in the form of four matching carved gargoyle heads that spit water into the lower bowl. Water in the lower bowl then cascades over the edges and into the pool below the fountain.

The fountain was gifted to the City of Ashland by Gwin S. Butler and Domingo Perozzi in 1916, after acquiring it in 1915 at the San Francisco Panama-Pacific Exhibition. The fountain was sculpted by Antonio Frilli, an Italian sculptor from Florence, Italy. It is carved out of Fiori di Peschi marble which is still quarried in the Friuli Venezia Giulia region of northeastern Italy.

The fountain sits on a concrete base and is part of a concrete terrace that was built to house it. Access to the terrace is by the central staircase from the lower parking area, two walking paths at the north and south, and a staircase from Granite Street at the west. The terrace is lit by light posts that flank each entrance.

By the 1980s, the fountain was in serious disrepair. In 1987, the fountain underwent a significant rehabilitation and restoration. The work was commissioned by the City of Ashland's Planning Director, John Fergonese and included bringing in sculptor Jeffrey Bernard to

restore and re-carve several elements. At this time, the original marble statue of a boy and duck was removed and replaced with a bronze facsimile. The original is currently stored at the Public Library. The upper bowl and pedestal were replaced. It appears that several dutchman repairs at the lower bowl were installed at this time, and that the gargoyles were also repaired, perhaps with dutchman repairs that have since been damaged or lost.

Over time, the site had seen other changes, including the removal of the historic light posts. These were replicated and reinstalled during the 1987 restoration. Based on historic photos from the early 1980s, the outer rim of the fountain pool was also raised and widened at this time.



Photo circa 1927 of the fountain, viewed from the steps to Granite Street.

Introduction



Butler-Perozzi Fountain, circa 1981 before restoration. Note the missing light posts and fountain bowls.



Butler-Perrozzi Fountain, undated. Note the water feature that spouts water from the outer rim of the fountain pool, toward the lower bowl. No sign of this feature is currently visible.

This page intentionally left blank.

Section Two

Methodology

ON-SITE ASSESSMENT

ARG Conservator Jennifer Pont was on site on May 26, 2022 to survey the fountain and coordinate with Parks and Maintenance personnel. A fountain consultant, Lance Dohman of Aquatic Environments was also on site to assess the fountain and its plumbing systems. The fountain was running at the time, which allowed for the team to assess the water effects and plumbing system, but prevented close up assessment of the marble and sounding of previous repairs. Items such as the integrity of the piping system between the pump vault and fountain, soundness of the mechanical connections between the various stacked elements that form the central feature, and the sanitary sewer lateral could not be evaluated under wetted conditions and without some damage to the installation. Despite these limitations, access to the fountain and the pump vault system was extensive and a thorough assessment was carried out.

COST ESTIMATE

Based on this survey, a series of recommendations were developed. A cost estimate was prepared by ARG Conservation Services (ARG/CS) and is included in Appendix C. Fountains endure substantial challenges to their integrity including the constant presence of treated water, thermal cycling from freeze-thaw cycles, vandalism, and multiple connections of dissimilar materials that deteriorate unevenly leading to failures of adjacent materials. The costs presented are based on an achievable goal of an enduring restoration to reset the present condition and combat the forces of nature and human interaction over a long-term horizon. The cost estimate assumes work will be carried out by professional ARG/CS conservators and durable fountain-specific equipment will be installed by experienced water feature contractors. These are intended for planning purposes only and should be updated in future design phases.

GUIDELINES

The recommendations in this report are based on The Secretary of the Interior’s Standards for the Treatment of Historic Properties (The Standards) with Guidelines for Preserving, Rehabilitating, Restoring, and Reconstructing Historic Buildings, and on the Code of Ethics of the American Institute for the Conservation of Historic and Artistic Works (AIC). The Standards provide general information for stewards of historic resources to determine appropriate treatments. They are intentionally broad in scope to apply to a wide range of circumstances, and are designed to enhance the understanding of basic preservation principles. They are neither technical nor prescriptive, but are intended to promote responsible preservation practices that ensure continued protection of historic resources. Further, the Code of Ethics of AIC calls for treatments to be “suitable to the preservation of the aesthetic, conceptual, and physical characteristics of the cultural property.” The Code of Ethics also requires an “informed respect for the cultural property, its unique character and significance, and the people or person who created it.” Treatments listed in this report respond to goals related to the preservation of the original intent and materials used in the creation of the Butler-Perozzi Fountain.

Section Three

Existing Conditions

SUMMARY OF CONDITIONS

During the on-site assessment the fountain, terrace, and main stairs were surveyed and photographed. Overall the fountain, terrace, and main stairs are in fair condition, with isolated elements in fair to poor condition. The following conditions were observed:

- There are multiple previous repairs to the marble fountain, some of which are in good condition, such as the dutchman repairs at the edge of the lower bowl. Some previous repairs show signs of loss and deterioration, including epoxy repairs on the skyward face of the lower bowl, and failure of joints around submerged dutchman.
- There is a through-unit crack on the base of the upper pedestal and several spalls including at the neck and base of the upper pedestal, the neck of the pedestal, and at decorative features of the lower pedestal.
- The joints between the marble units of the bottom bowl and pedestal are heavily deteriorated. Water traveling through joints likely contributes to water loss experienced by the system when it is running, contributing to flow issues.
- At the fountain pool outer edge, perimeter terrace walls, and light posts, spalled concrete has revealed embedded ferrous reinforcement. In some areas the exposed reinforcement is corroding and causing further deterioration.
- There are cracks, spalls, and failed previous repairs at several stairs at the top and bottom of the main stair.
- There are cracks in the surface finish on the north and south cheek walls of the main stair.
- There are water flow issues including excess spraying from the bronze duck beak, uneven flow from the uppermost bowl due to an unsecure connection, and irregular flow through the lionhead scuppers. Irregular flow and splashing is causing uneven wear across most of the carved elements.
- The concrete of the fountain bowl, terrace, and stairs is heavily soiled.

Existing Conditions

FOUNTAIN

Overall, the fountain is in fair condition. The following conditions were observed and are listed from the top of the fountain and down. For a list in order of recommended repair, see the Recommendations Section. The following conditions were observed:

- There are general flow issues with the fountain. Water has to be routinely added to the system due to water loss. Water loss can take several forms including constant flow into an overflow drain that normally maintains the water level during rain events, leaking piping, and splashing. We were informed that the fountain is topped off manually or via a battery-operated timer in the pump vault area.
- Other assemblies such as an overflow drain and fittings to keep the fountain water moving in a clockwise fashion have been periodically retrofitted on the fountain to keep it operating, but none were found with historical significance. Periodic installation of mechanical equipment separated by larger renovation events throughout the course of a fountain's life is commonplace. When installed more than a hundred years ago, fountains were once-through systems where water was simply discharged to a water way or sewer after one trip through the fountain. Over time, pumping schemes were installed to recirculate water via demolition of portions of the lower pool. While recirculation of fountain water preserves a valuable resource many rounds of invasive modifications have taken place over time to capture and repressurize fountain



Water splashes out of the east end of the fountain, at the top of the stairs.



Water splashes out of the east end of the fountain, at the top of the stairs.

Existing Conditions

waters which commonly develop into leaks as the layers of patching inevitably fail. Maintenance of sterilization to avoid accumulation of algae and bacteria have required water treatment chemicals including chlorine tablets that accelerate damage to fountain construction materials.

- As the main point of entry for water into the system is the swan's mouth in the bronze sculpture, this results in over-spray and heavier flow on that side of the fountain. This condition has impacted other conditions listed in this section.
- The bronze statue at the top of the fountain is a replica of the original marble statue and was installed in the 1987 restoration. The bronze is in fair condition and is showing signs of cupric oxidation; it is turning green in some areas whereas the rest of the statue has a typical brown patina. The bronze should be cleaned and given a waterproof protective coating to prevent oxidation.
- The upper bowl is a replacement, likely from the 1987 restoration and is in good condition. The type of marble used was reportedly the same marble the rest of the fountain is made from, but varies slightly in color. This is not unusual from quarries that have been active for long periods of time. The bowl does have some graffiti ghosting visible on the north side of the bowl, but most of the graffiti has been successfully removed.
- The pedestal supporting the upper bowl is in poor condition. It has spalls at the upper and lower lips, and a through-unit crack in its base. Although it could not



Water flows unevenly off the north east edges of the bowls. Note that the flow out of the lions is not smooth.



Bronze discoloration at the fountain's statue.



Cracks and spalls at the upper pedestal.

Existing Conditions

be visually verified, there does not appear to be any vertical reinforcing such as metal rods set in grout pockets between this pedestal and the upper bowl.

- The middle bowl is in fair condition. It appears to be original and shows some uneven wear on the east edge of the bowl, likely related to the flow issues in the fountain. Water was likely meant to flow to the lower bowl through the open mouths of the lion's heads on the underside of the bowl. Currently, the flow out these areas is uneven and may be related to water pressure/flow issues, or blockages in the openings.
- The lower pedestal is in fair to poor condition, with spalls, uneven weathering, and flow issues. While most spalls are superficial and occur around the scrolls around the spitting gargoyles, two gargoyles show significant loss of their facial features. The valves or other mechanisms that control flow to the gargoyles was not detected. It is possible that these connections are broken and contributing to water flow that emanates from various joints and cracks in the lower pedestal.
- Two of the gargoyles at the lower pedestal are in poor condition. Two are missing most of their faces. One of these has a piece of piping sticking out of its mouth. This appears to have been a recent attempt at vandalism. It should be noted that water still flows from this spout. The other that is missing its face no longer spits water. These two gargoyles may have been repaired in the 1987 restoration, but these repairs have failed.



Spalls at the upper pedestal.

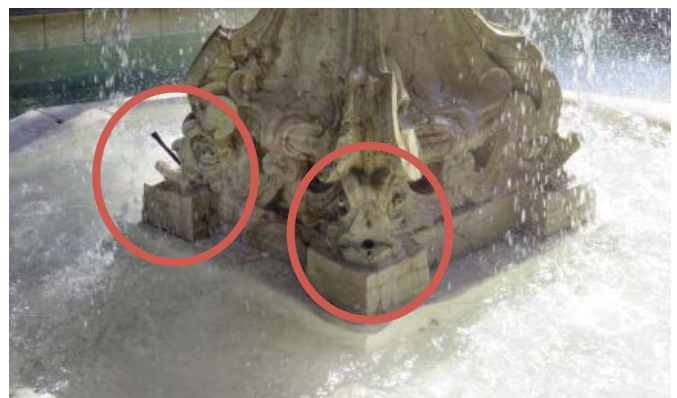

Damaged gargoyles at lower pedestal. Note the pipe sticking out of the element on the left.



Weathered veining in lower pedestal. Note the dutchman repair indicated with an arrow.

Existing Conditions

- The lower bowl is in fair condition. While the marble is in fair condition, the joints between the bowl sections are in very poor condition. They are heavily eroded and missing in large areas. This likely contributes to water loss and flow issues at the fountain.
- There are several rounds of repair on the lower bowl, including epoxy repairs and dutchman repairs. The epoxy repairs are in poor condition, as the marble around the repairs has continued to weather, resulting in slightly raised patches. The condition of the dutchman repairs varies. While most are still in good condition there are isolated areas of failed joints that should be repaired. Water flows from various joints and gaps in the lower bowl. Its origin could include gaps between the upper structure or via water conveyance through a cylindrical chase that typically contains the piping that delivers water to the upper portions of the assembly.
- The pool of the fountain is in poor condition, with large areas of cracked and missing swimming pool plaster. The plaster shows signs of previous patching, and many of the interfaces of these patches have failed and exhibit large cracks. Some of the pool plaster extends above the waterline onto the lower podium and has experienced significant delamination. In general, pool plaster should be continually submerged as it can dry out, check, crack, and fall apart. Hence, if a fountain is to be drained in the wintertime or experiences periods with no water such as shutdowns during extreme drought conditions, swimming pool plaster is a poor choice if lining material.



Crack (red) and dutchman repairs (blue) in lower bowl. Note the open joint between the plaster and the marble.



Previous repairs and open joints at lower bowl. Note the plaster failure and exposed concrete at the bottom right.

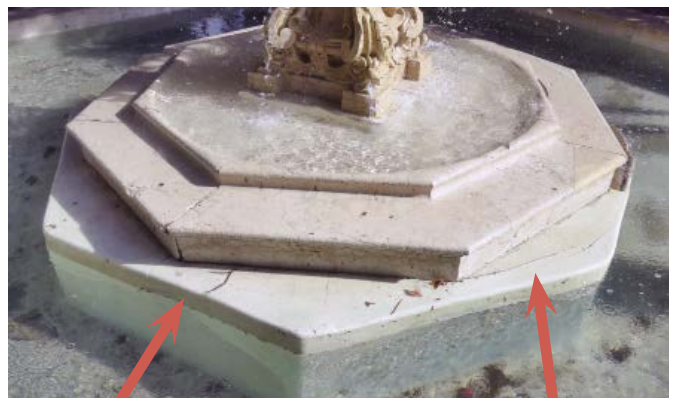

Cracks in plaster over concrete base.

Existing Conditions

- The tile line at the outer edge of the pool is in fair to poor condition. There is a large area of missing tiles at the east side of the fountain, and the tiles are weathered and stained. A tile band is a necessary feature to maintain a submerged condition for the pool plaster and to provide a smooth surface for cleaning scum that tends to accumulate at the waterline.. Based on historic photos, this tile line was added in the 1987 restoration.
- The outer rim of the pool is in poor condition, with a large area of loss and exposed ferrous reinforcement at the east side of the fountain. This appears to have been a recurring problem area, as there are signs of at least four repair campaigns. Additionally, based on historic photos the outer rim was made thicker and taller in the 1987 restoration, likely in response to water issues at this wall. The delamination issues at this wall suggest that it is another avenue for water to escape the fountain system.



Plaster loss at concrete base. Note plaster loss below the water, on the floor of the pool.



Missing and soiled perimeter tiles.



Concrete loss at outer rim of fountain pool.

Existing Conditions



Concrete cracking, spalls, and soiling at outer rim of fountain pool.



Concrete cracking, spalls, and soiling at outer rim of fountain pool.

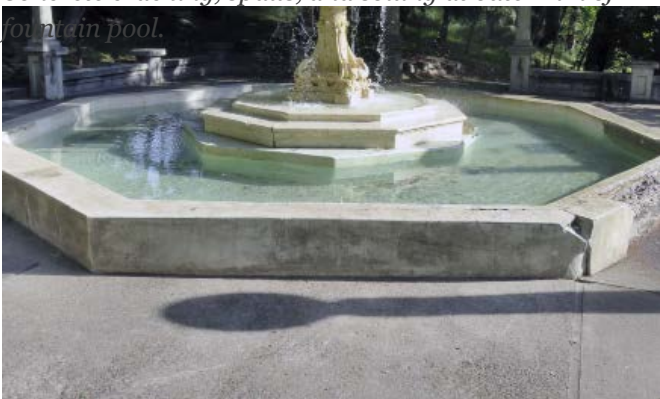

Concrete cracking, spalls, and soiling at outer rim of fountain pool.

Existing Conditions

TERRACE

Overall the terrace is in good to fair condition, with some areas in poor condition. The following conditions were observed:

- Several of the column capitals are in poor condition, with corrosion of the embedded ferrous reinforcement. This has caused delamination of the surface finish, cracking, and spalling. In some locations the ferrous reinforcement has been exposed. Many of these areas show signs of previous repair.
- The light posts are in good to poor condition. They exhibit similar signs of deterioration to the column capitals with delamination of the surface finish, cracking, and spalling. There are also areas of exposed ferrous reinforcement, and signs of previous repair.
- The concrete walls are in good condition, but like the columns and light posts, they are heavily soiled.
- While all the plastic globes on the light posts are intact, several are yellowing due to UV exposure. It is unknown if these lights still function.
- There are several areas of graffiti ghosting on the skyward face of the concrete walls. The graffiti has been mostly removed but some residual color is still visible on the concrete.
- The flat concrete is in fair condition, with cracking and surface loss on the north end.
- The flat paving has inset wood strips. These strips are beginning to warp in some areas due to moisture in the wood.



Concrete cracking, spalls, and soiling at terrace column.



Concrete cracking, spalls, and soiling at terrace columns.



Concrete cracking, spalls, and soiling at light posts.

Existing Conditions



Concrete cracking and spalls at light post.



Graffiti ghosting on terrace wall.



Concrete cracks (red) and warped wood strips in terrace floor (blue).

Existing Conditions

MAIN STAIRCASE

The main staircase to the fountain leads up the slope from the parking area to the east and is in fair condition. Additional paved paths to the north, south, and west were not part of this assessment. The following conditions were observed:

- Overall the stairs are in good condition, with some areas in poor condition. There are spalls and cracks in stairs at the base and top of the staircase. There are previous repairs visible on the top steps, and some of these have failed.
- The stair walls are in fair condition. There are cracks in the cheek walls. Several of these cracks are visible on the inner and outer faces of the walls and may be due to water infiltration at the terrace or movement. Although most of the water that splashes out of the fountain evaporates naturally, it is possible that water is leaking from the fountain pool, particularly around the drain and other embedded items and is migrating beneath the concrete paving and stairway, compromising its integrity.



Cracks in cheek wall and failed repairs and cracks in the stairs.



Uneven and failed repairs at the lower stairs.



Failed repairs and small spalls at lower stairs.

Existing Conditions



Cracks in the cheek wall. This crack is also visible at the exterior face.



Cracks in the outer face of the staircase. This crack is also visible at the interior face.



Cracks in the outer face of the staircase.

This page intentionally left blank.

Section Four

Recommendations

Based on the conditions observed at the Butler-Perozzi Fountain, the following recommendations are made. As with the existing conditions, the following recommendations are organized by location, starting with the fountain and moving to the outer edges of the site. They are generally listed in order of priority, with high-priority items listed first.

FOUNTAIN

- The pedestal supporting the upper bowl is in poor condition and should be replaced. The noted conditions affect the structural stability of this unit, and the upper bowl has been known to rock. Should it fall, this poses a significant risk to the upper bowl itself and to the lower elements of the fountain as would impact them when toppled. As these elements are replacements, they should be replaced in kind. Historic photos may be used to achieve a level of detail more consistent with the original pedestal.
- Water flow issues should be addressed. Blockages should be cleared so that water flows evenly out of the lion's heads on the middle bowl rather than over the rim of the middle bowl. This will prevent uneven wear and erosion on the rim. Openings could be re-drilled, and brass escutcheons installed to direct the flow downward to minimize the erosive effects of splashing on the lower pedestal.
- The joints, especially those in the lower bowl, should be repaired. A tile grout appropriate for marble and partially submerged conditions should be used.
- The lower pool and outer rim of the fountain pool should be demolished and replaced. Historic photographs indicate that this wall has long had water issues and the plaster and tile installation is both prone to failure and is non-historic. There are multiple failed repairs and corroding reinforcement. Furthermore, the installation of new piping and reliable

Recommendations

fountain mechanical equipment would involve extensive saw-cutting, demolition, and patching, giving rise to future leaks along these routes if the present floor was maintained. We recommend a monolithic concrete structure that would extend from the center footing through the bottom of the pool and vertically to create a new outer rim (viewed as a “U” shape in cross-section). This structure would involve placement of a new aggregate base, coated reinforcing steel, and premixed shotcrete containing integral colorant and a waterproofing admixture. This new structure would accommodate reliable fountain mechanical components and the challenges of a tile line or plaster and their typical 10-year replacement cycles would be avoided. In sum, an economical grey concrete pool more closely resembles the subdued historic installation and provides a multiple of durability vs. adding more layers to a failing existing structure.

- New concrete should tuck under the marble at the lower bowl but should not be in direct contact. A separate joint between the concrete and marble should be maintained.
- The lower pedestal should be repaired. Spalls should be patched with a compatible material, with large areas of loss repaired using dutchman and cracks filled with appropriate crack repair materials matching the existing material. If water flow cannot be restored without significant intervention into the plumbing at the lower pedestal, sealing off of the affected gargoyles should be considered. Should the fountain be de-constructed in the future, these

features could be easily restored with the additional intervention.

- Cracks and spalls in the lower bowl should be repaired. The previous dutchman repairs should be repointed as needed. Large areas of missing or spalled material should be replaced in kind with a dutchman repair. Existing joints and carved features should be accurately replicated.
- Failing repairs should be repaired or removed and replaced. The joints of dutchman repairs that have failed should be re-grouted. Epoxy repairs that sit proud of the weathered marble should be refinished to be flush with the marble. This will prevent continued uneven erosion of the softer marble at the edges of the epoxy.
- The bronze statue at the top of the fountain is showing signs of oxidation and turning green. The bronze should be cleaned and given a waterproof protective coating.
- When the upper bowl is removed for replacement of the pedestal, the graffiti ghosting should be treated. Note that the previous intervention did remove most of the paint, and additional methods such as poulticing may remove remaining paint and pigment from the grain of the marble.

Recommendations

PLUMBING RECOMMENDATIONS

- A new leak-resistant pool is recommended to contain the falling waters from the fountain elements. The structure also performs the function of reliable water control with devices imbedded within the concrete structure. On the walls of the pool, two new cast-in brass overflow drains will manage accumulation of rainwater and an automatic fill sensor in a brass housing will trigger a solenoid valve to add water to the fountain. The floor should contain two suction drains with screens, two eyeball fittings to circulate water in the pool, and a drain valve with tamper-proof hardware to thoroughly drain the fountain when required.
- The depth of the pool was 19.25" at the time of the assessment. This is beyond the maximum allowable depth by most municipal codes or regulations, with standard designs between 12" and 18" typical and 18" being the maximum allowable depth in most cases. The depth of a new pool should be no greater than 16" to allow for potential clogging of the overflow drains.
- The mechanical items within the pool will be connected to new copper piping¹ serving the bronze duck, uppermost bowl adjacent to the duck, and gargoyles. These flow elements should be individually controllable at the pump vault or in a concrete box adjacent to the fountain.
- Historic photographs show jets emanating from the pool wall and landing short of the center fountain.

¹ Copper is recommended for piping of one inch or less.

These could be plumbed in as an alternate and once again should be individually valved for precise control.

- All new pressurized water supply piping and suction piping should be installed from fountain to the location of the pump vault. This piping can be SCH 40 PVC.
- While the existing vault and pump functions adequately, a custom-built system has the advantages of direct compatibility with the water control elements installed in the new pool. A pre-engineered system² could include features such as a built-in control panel with pump and lighting (optional) time clocks, an automatic fill solenoid, cartridge filtration, a sump pump to collect incident water, and an erosion feeder for sterilization. An additional timing circuit to control lighting at the terrace can also be provided within the vault lid. The existing backflow device could be reused if needed.

² Such as those constructed by Roman Fountains, The Fountain People, or equal. See Appendix B for a cut sheet by Roman Fountains.

Recommendations

TERRACE

- Cracked, spalling and deteriorated concrete should be removed and repaired.
- Exposed ferrous elements should be cleaned and treated before repairing.
- Cracks in the concrete should be cleaned. Cracks wider than 1/4" should be routed and repaired. Note that smaller cracks may also be repaired but may not be necessary.
- The wood strips between concrete blocks should be replaced in kind.
- The concrete should be cleaned using a biodegradable, non-acidic cleaner and low-pressure power washer. In order to prevent streaking and wand marks, a distance of at least 6 inches should be maintained between the surface and the tip of the power wash wand equipped with a fan tip 60 degrees or greater.
- Graffiti ghosting may be addressed during the cleaning process using non-acidic biodegradable paint stripper.
- The electrical for the light posts should be tested and repaired/replaced as needed.
- The plastic globes should be replaced with non-yellowing UV resistant plastic or frosted glass.

STAIRS

- Spalls and cracks on the stair treads should be repaired. Failed repairs should be removed and replaced.

- Cracks in the cheek walls should be routed and repaired. Care should be taken to match the existing color and texture.
- The concrete should be cleaned using a biodegradable, non-acidic cleaner and low-pressure power washer. In order to prevent streaking and wand marks, a distance of at least 6 inches should be maintained between the surface and the tip of the power wash wand equipped with a fan tip 60 degrees or greater.
- While not included in the scope of this project, as it is not a signed or publicized pathway, the staircase from Granite Street should be studied for accessibility, and a handrail should be added if needed.



*Staircase to Granite Street, to the west of the terrace.
Note that this is not a signed or publicized pathway.*

Recommendations

DISCUSSION: REHABILITATION VS. REPLACEMENT

The fountain overall is in fair condition, and the terrace is in good to fair condition. A project such as the one outlined in our recommendations followed by regular maintenance, will extend the life of the fountain for another 30-50 years. Maintenance is a key factor in the lifespan of a rehabilitated or new fountain. Even a completely new fountain would require maintenance on a similar timeline.

Previous discussions about the fountain have included the possibility of replacement of the marble components in a more durable material such as granite (since the basin and mechanical systems will be replaced in their entirety, the only element that would be considered rehabilitated would be the central tiered element). When considering rehabilitation versus replacement, it is important to understand how each option will extend the life of the fountain and affect the historical significance of the fountain. Note that most of the significant intervention included in our recommendations is related to the concrete work of the fountain and terrace, not the marble fountain itself. Replacement of the concrete or marble elements with granite facsimiles would have a major impact on the aesthetic of the fountain, in addition to the upfront cost of the material and workmanship to replicate the existing level of carving detail in the marble.

Repair of the marble elements of the fountain are currently priced at \$78,894.50 in the cost estimate. Replacement of these pieces in granite and the cost to carve them to match the historic configuration could cost the same, if not more, and it would be very difficult to match the exact historic configuration.

APPENDIX A:

Existing Conditions Survey

This page intentionally left blank.

Existing Conditions - Fountain



Condition	
	Concrete Spall
	Marble Spall
	Concrete Crack
	Concrete Hairline Crack
	Marble Crack
	Marble Hairline Crack
	Open Joint
	Failed Repair (Marble Only)
	Previous Repair (Marble Only)

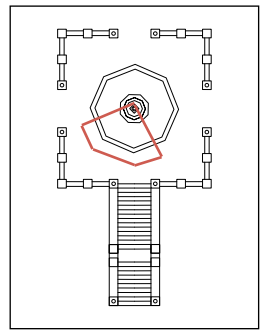

Key Plan North
↓

Existing Conditions - Fountain



Condition	
	Concrete Spall
	Marble Spall
	Concrete Crack
	Concrete Hairline Crack
	Marble Crack
	Marble Hairline Crack
	Open Joint
	Failed Repair (Marble Only)
	Previous Repair (Marble Only)

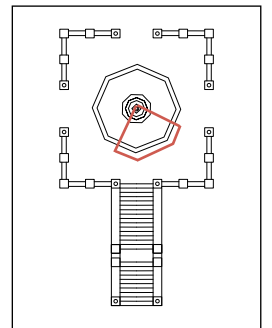

Key Plan North

Existing Conditions - Fountain



Condition	
	Concrete Spall
	Marble Spall
	Concrete Crack
	Concrete Hairline Crack
	Marble Crack
	Marble Hairline Crack
	Open Joint
	Failed Repair (Marble Only)
	Previous Repair (Marble Only)

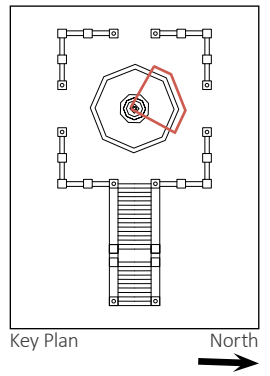

Existing Conditions - Fountain



	Condition
	Concrete Spall
	Marble Spall
	Concrete Crack
	Concrete Hairline Crack
	Marble Crack
	Marble Hairline Crack
	Open Joint
	Failed Repair (Marble Only)
	Previous Repair (Marble Only)

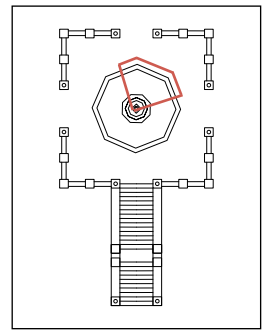

Key Plan

North

Existing Conditions - Fountain



Condition	
	Concrete Spall
	Marble Spall
	Concrete Crack
	Concrete Hairline Crack
	Marble Crack
	Marble Hairline Crack
	Open Joint
	Failed Repair (Marble Only)
	Previous Repair (Marble Only)

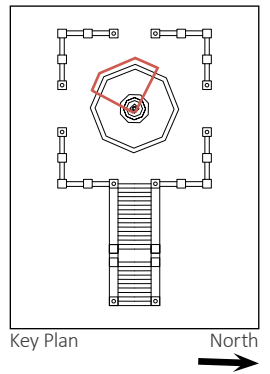

Existing Conditions - Fountain



Condition	
	Concrete Spall
	Marble Spall
	Concrete Crack
	Concrete Hairline Crack
	Marble Crack
	Marble Hairline Crack
	Open Joint
	Failed Repair (Marble Only)
	Previous Repair (Marble Only)

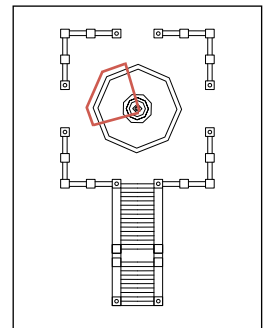

Key Plan North

Existing Conditions - Fountain



Condition	
	Concrete Spall
	Marble Spall
	Concrete Crack
	Concrete Hairline Crack
	Marble Crack
	Marble Hairline Crack
	Open Joint
	Failed Repair (Marble Only)
	Previous Repair (Marble Only)

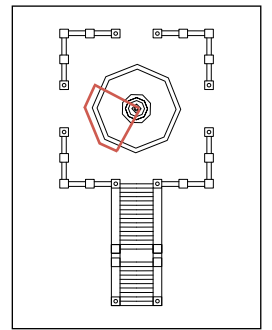

Key Plan North

Existing Conditions - Terrace



Condition	
	Concrete Spall
	Marble Spall
	Concrete Crack
	Concrete Hairline Crack
	Marble Crack
	Marble Hairline Crack
	Open Joint
	Failed Repair (Marble Only)
	Previous Repair (Marble Only)

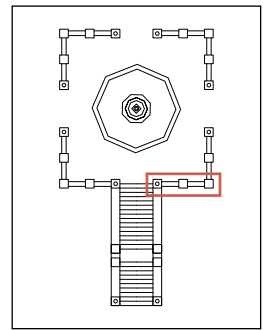

Key Plan North

Existing Conditions - Terrace



	Condition
	Concrete Spall
	Marble Spall
	Concrete Crack
	Concrete Hairline Crack
	Marble Crack
	Marble Hairline Crack
	Open Joint
	Failed Repair (Marble Only)
	Previous Repair (Marble Only)

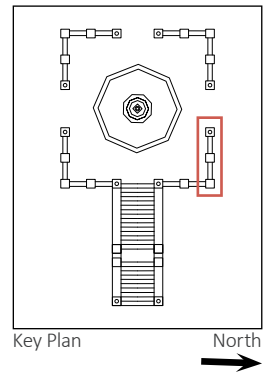

Existing Conditions - Terrace



Condition	
	Concrete Spall
	Marble Spall
	Concrete Crack
	Concrete Hairline Crack
	Marble Crack
	Marble Hairline Crack
	Open Joint
	Failed Repair (Marble Only)
	Previous Repair (Marble Only)

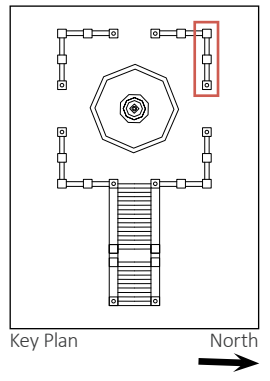

Existing Conditions - Terrace



Condition	
	Concrete Spall
	Marble Spall
	Concrete Crack
	Concrete Hairline Crack
	Marble Crack
	Marble Hairline Crack
	Open Joint
	Failed Repair (Marble Only)
	Previous Repair (Marble Only)

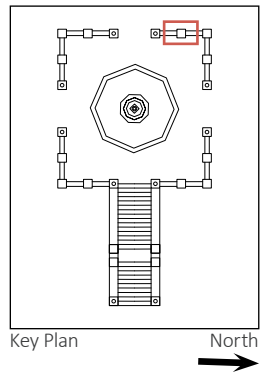

Existing Conditions - Terrace



Condition	
	Concrete Spall
	Marble Spall
	Concrete Crack
	Concrete Hairline Crack
	Marble Crack
	Marble Hairline Crack
	Open Joint
	Failed Repair (Marble Only)
	Previous Repair (Marble Only)

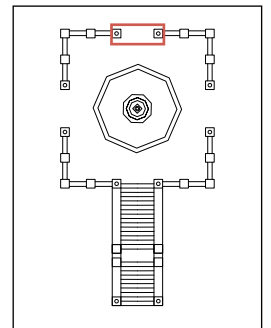

Key Plan North

Existing Conditions - Terrace



Condition	
	Concrete Spall
	Marble Spall
	Concrete Crack
	Concrete Hairline Crack
	Marble Crack
	Marble Hairline Crack
	Open Joint
	Failed Repair (Marble Only)
	Previous Repair (Marble Only)

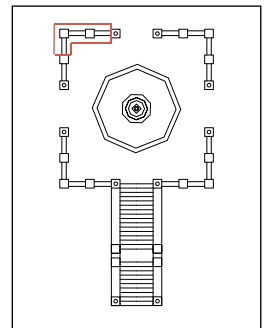

Key Plan North

Existing Conditions - Terrace



Condition	
	Concrete Spall
	Marble Spall
	Concrete Crack
	Concrete Hairline Crack
	Marble Crack
	Marble Hairline Crack
	Open Joint
	Failed Repair (Marble Only)
	Previous Repair (Marble Only)

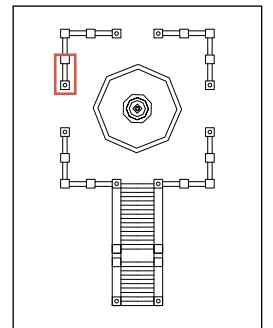

Key Plan North

Existing Conditions - Terrace



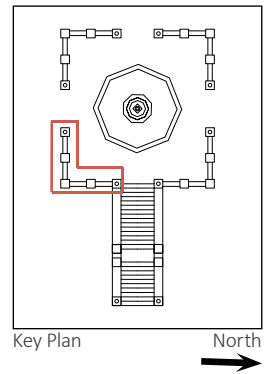

Condition	
	Concrete Spall
	Marble Spall
	Concrete Crack
	Concrete Hairline Crack
	Marble Crack
	Marble Hairline Crack
	Open Joint
	Failed Repair (Marble Only)
	Previous Repair (Marble Only)

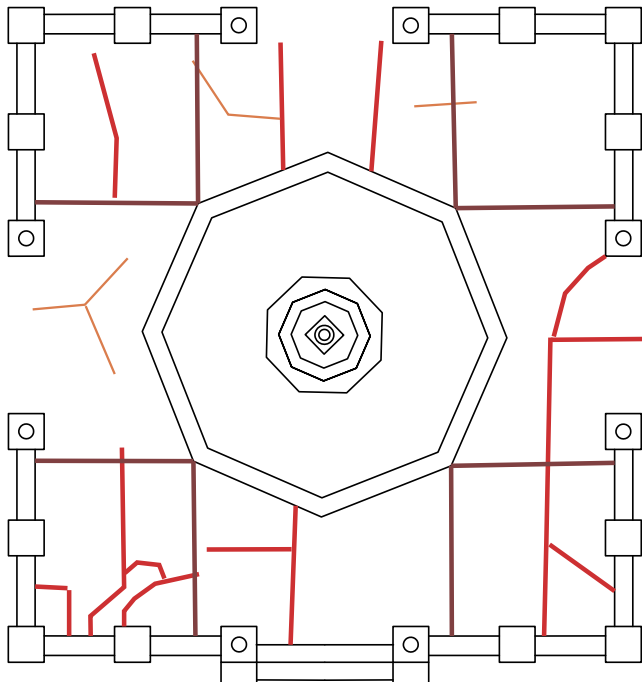

Existing Conditions - Terrace



Condition	
	Concrete Crack
	Concrete Hairline Crack
	Wood Divider

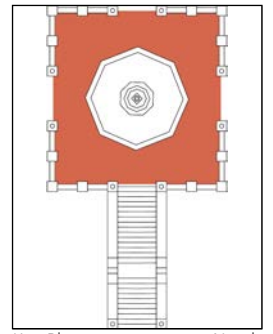

Key Plan North

Existing Conditions - Stairs



Condition	
	Concrete Spall
	Marble Spall
	Concrete Crack
	Concrete Hairline Crack
	Marble Crack
	Marble Hairline Crack
	Open Joint
	Failed Repair (Marble Only)
	Previous Repair (Marble Only)

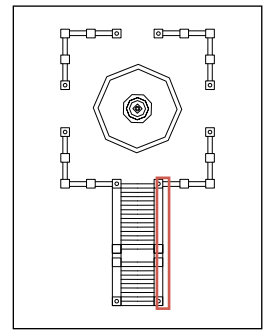

Key Plan North
↓

Existing Conditions - Stairs



Condition	
	Concrete Spall
	Marble Spall
	Concrete Crack
	Concrete Hairline Crack
	Marble Crack
	Marble Hairline Crack
	Open Joint
	Failed Repair (Marble Only)
	Previous Repair (Marble Only)

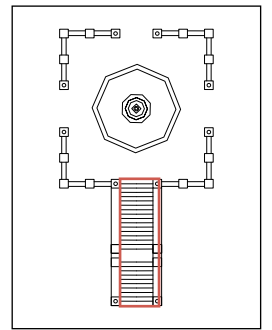

Key Plan North

Existing Conditions - Stairs



Condition	
	Concrete Spall
	Marble Spall
	Concrete Crack
	Concrete Hairline Crack
	Marble Crack
	Marble Hairline Crack
	Open Joint
	Failed Repair (Marble Only)
	Previous Repair (Marble Only)

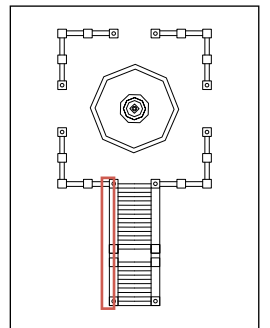

Key Plan North

Existing Conditions - Stairs



Condition	
	Concrete Spall
	Marble Spall
	Concrete Crack
	Concrete Hairline Crack
	Marble Crack
	Marble Hairline Crack
	Open Joint
	Failed Repair (Marble Only)
	Previous Repair (Marble Only)

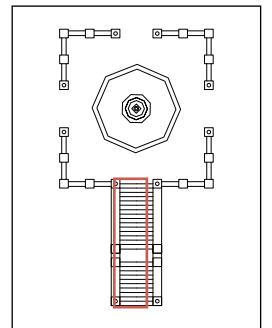

Key Plan North
↓

This page intentionally left blank.

APPENDIX B:

Roman Fountains Custom
Vault Cut Sheet



(877) 794-1802

RDP-1 SERIES, DIRECT-BURIAL FIBERGLASS PUMP VAULT

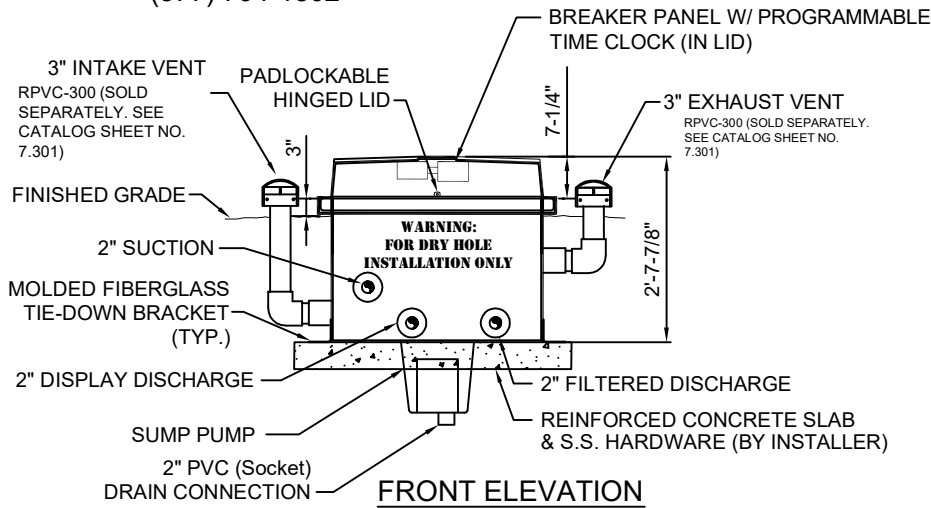

SHOWN WITH OPTIONAL LIGHTING CIRCUIT

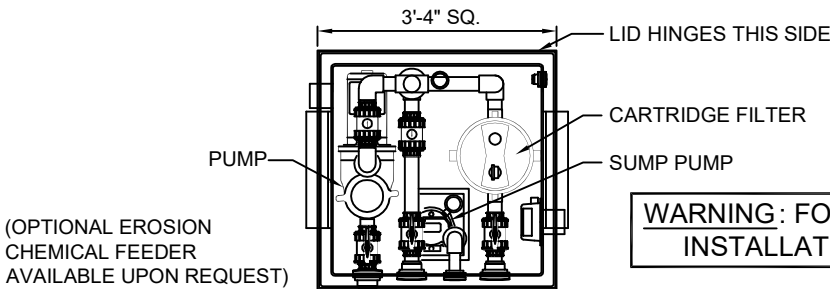

WARNING: FOR 'DRY HOLE' INSTALLATION ONLY!



TECHNICAL DATA		
MODEL #	PUMP HP	AVAILABLE SYSTEM POWER OPTIONS
RDP-1-050	1/2	120/208-240V, 1PH
RDP-1-075	3/4	120/208-240V, 1PH
RDP-1-100	1	120/208-240V, 1PH, or 208-240-460V, 3PH
RDP-1-150	1 1/2	208-240V, 1PH, or 208-240-460V, 3PH
RDP-1-200	2	208-240V, 1PH, or 208-240-460V, 3PH
RDP-1-300	3	208-240V, 1PH, or 208-240-460V, 3PH

*NOTE THREE-PHASE VAULTS REQUIRE AN OPTIONAL U.L. 508 LISTED CONTROL PANEL UPGRADE.

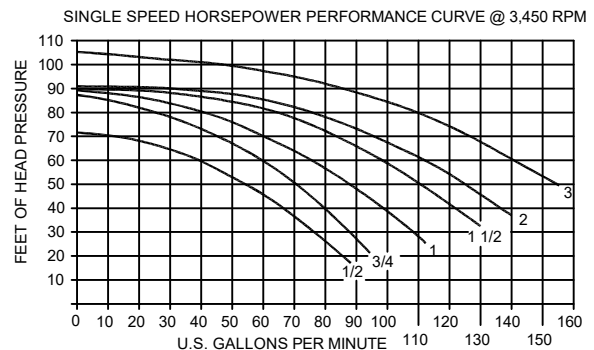

SPECIFICATION DATA: : Series 1 Direct Burial Pump Vault, consisting of a 3'-4" sq. x 2'-8" deep heavy duty FRP vault with white gel-coat interior and brown gel-coat exterior, furnished with 36" sq. fiberglass reinforced plastic lid with stainless steel piano hinge attachment and lock hardware (LOCK BY INSTALLER), containing a self-priming display pump with integral suction strainer, RCCF-050; 50 sq. ft. cartridge filter unit, 3" vent connections with 105 CFM vent fan, 2" floor drain; RTCP-PCLC; UL listed time clocks and power distribution breakers (Class A GFCI as required). Unit is pre-wired, pre-plumbed (Schedule 80 PVC) and factory tested prior to shipment. See power requirement above.

DESIGN/APPLICATION DATA: Roman Fountains RDP-Series 1, direct burial pump stations are designed for small fountains where concrete pump stations are not practical and interior mechanical space is not available. All units are factory assembled and tested prior to shipment to job site, minimizing installation and maintenance costs. Systems can be furnished with optional fill manifold, G.F.C.I. protected lighting circuit and erosion feeder; consult factory.

- NOTES:**
- Information on this sheet represents manufacturers' typical unit. Variations may occur in specified unit to meet fountain design and mechanical requirements.
 - Hatch opening must be located in flood-safe area.
 - Slope finished grade away from pump module.
 - Protect pump module gravity drain from back flow and gas.
 - Top of pump module must be at, or below lowest pool water level.
 - Options for Tile-Set Hatch and Diamond Plate Hatch available. Consult factory.
 - Due to our continuing product improvement program, Roman Fountains reserves the right to change the specifications w/o notice.

DRAWING NO.
7.201

APPENDIX C:

Cost Estimate by ARG/CS

Butler Fountain Conservation Repair - Rough Estimate

Estimate dated 7/25/2022

Bid Item 1:	General Conditions/Project Management	Cost	OH @ 15%	Profit @ 10%	Total
	Safety Compliance	\$750.00	\$ 112.50	\$ 86.25	\$948.75
	Protection Materials	\$7,000.00	\$ 1,050.00	\$ 805.00	\$8,855.00
	Fencing/Temp Restroom	\$4,500.00	\$ 675.00	\$ 517.50	\$5,692.50
	Access Equipment (adders & scaffold)	\$1,500.00	\$ 225.00	\$ 172.50	\$1,897.50
	Principal	\$10,800.00			\$10,800.00
	Project Management	\$18,000.00			\$18,000.00
		42,550	2,062.50	1,581.25	\$46,193.75
Bid Item 2:	Construction Documents				
	Conservator	4,200.00			\$4,200.00
	Architect	10,500.00			\$10,500.00
		14,700.00		Subtotal:	\$14,700.00
Bid Item 2:	Mock-Up Phase				
	Conservator	5,600.00			\$5,600.00
	Mason	3,840.00	\$ 576.00	\$ 441.60	\$4,857.60
	Materials	1,200.00	\$ 180.00	\$ 138.00	\$1,518.00
		10,640.00		Subtotal:	\$11,975.60
Bid Item 3:	Fountain Repair Inner Basin & Column				
	Conservator	14,000.00			\$14,000.00
	Mason 1	12,800.00	\$ 1,920.00	\$ 1,472.00	\$16,192.00
	Mason 2	12,800.00	\$ 1,920.00	\$ 1,472.00	\$16,192.00
	Dutchman - specialist	13,200.00	\$ 1,980.00	\$ 1,518.00	\$16,698.00
	Materials (marble, crack repair, repointing, caulking, cleaning agents, coating, aesthetic integration)	12,500.00	\$ 1,875.00	\$ 1,437.50	\$15,812.50
		65,300.00		Subtotal:	\$78,894.50
Bid Item 4:	Fountain Replacement Outer Rim & Basin				
	Conservator 1	2,100.00			\$2,100.00
	Mason 1	19,200.00	\$ 2,880.00	\$ 2,208.00	\$24,288.00
	Mason 2	19,200.00	\$ 2,880.00	\$ 2,208.00	\$24,288.00
	Mason 3	19,200.00	\$ 2,880.00	\$ 2,208.00	\$24,288.00
	Mason 4	12,800.00	\$ 1,920.00	\$ 1,472.00	\$16,192.00
	Materials (concrete, forms, mixing equipment, tools, base, waterproofing membrane, pointing/caulking)	30,000.00	\$ 4,500.00	\$ 3,450.00	\$37,950.00
		102,500.00		Subtotal:	\$129,106.00
Bid Item 5:	Bronze Conservation				
	Conservator 1	4,200.00			\$4,200.00
	Conservator 2	2,800.00			\$2,800.00
	Materials (cleaning, corrosion treatment, waxing, coating)	800.00	\$ 120.00	\$ 92.00	\$1,012.00
		7,800.00		Subtotal:	\$8,012.00
Bid Item 6:	Terrace Masonry Cleaning & Repair				
	Conservator 1	14,000.00			\$14,000.00
	Mason 1	12,800.00	\$ 1,920.00	\$ 1,472.00	\$16,192.00
	Mason 2	12,800.00	\$ 1,920.00	\$ 1,472.00	\$16,192.00
	Materials (concrete, concrete crack repair, cleaning agents, pressure washer, mortar)	30,000.00	\$ 4,500.00	\$ 3,450.00	\$37,950.00
		69,600.00		Subtotal:	\$84,334.00
Bid Item 7:	Fountain Upgrade Allowance				
	Conservator 1	2,100.00			\$2,100.00
	Fountain Installation	22,400.00	\$ 3,360.00	\$ 2,576.00	\$28,336.00
	Materials (plumbing, valves, water treatment, controls - design still needed)	60,000.00	\$ 9,000.00	\$ 6,900.00	\$75,900.00
		84,500.00		Subtotal:	\$106,336.00
Bid Item 8:	Documentation				
	Conservator 1	14,000.00			\$14,000.00
		14,000.00		Subtotal:	\$14,000.00
Bid Item 9:	Insurance (2%)				
	Insurance	9,871.04			9,871.04
					9,871.04
				Grand Total:	\$503,422.89

Recommended ROM: \$475,000 - \$515,000

Assumptions:

Conservator rate 175/hr
 Project Manager 180/hr
 Architect 180/hr
 Principal 225/hr
 Mason journeyman 150/hr (subcontractor)

Exclusions:

Permit Fees and Bonds
 Travel and per diem
 Terrace Features Indicated in Conservation Report - not all stairs included
 Walkways and stairs beyond the primary staircase are not included
 Electrical and lighting upgrades or repairs

SAN FRANCISCO

Pier 9, The Embarcadero
Suite 107
San Francisco, California 94111
T: 415.421.1680
F: 415.421.0127

ARGcreate.com

LOS ANGELES

360 E. 2nd Street
Suite 225
Los Angeles, CA 90012
T: 626.583.1401

PORTLAND

720 SW Washington Street
Suite 605
Portland, OR 97205
T: 971.256.5324